

# Pallet

## 110/120



110/120

- One way
- Fits air pallet
- Cost effective
- Nestable - reduces freight costs
- Easy and safe to handle
- Environment friendly - 100% recyclable
- Maintenance free
- Hygienic and clean
- Safety rims (optional)



### Specifications

DIMENSIONS		
Dimensions (L / W / H)	1,200 / 1,000 / 130 mm	47.24 / 39.37 / 5.1 in
Dimensions with runners (L / W / H)	1,200 / 1,000 / 140 mm	47.24 / 39.37 / 5.5 in
LOGISTICS		
Weight	5.8 KG	12.7 LB
Weight with runners (120)	7.8 KG	17.1 LB
Maximum load Dynamic	800 KG	1,764 LB
Maximum load Dynamic with runners (120)	1,000 KG	2,204 LB
Maximum load Static	1,600 KG	3,527 LB
Maximum load Static with runners (120)	2,000 KG	4,409 LB
Pallets per stack	60	
Units per 20 / 40 / 40 HC	600 / 1,235 / 1,420	
MATERIAL		
Material	PP/HDPE recycled or virgin	
Color	Black (recycled)	

\* Load capacities are based on evenly distributed loads and can vary according to the type of load.

### Technical Drawing (mm)

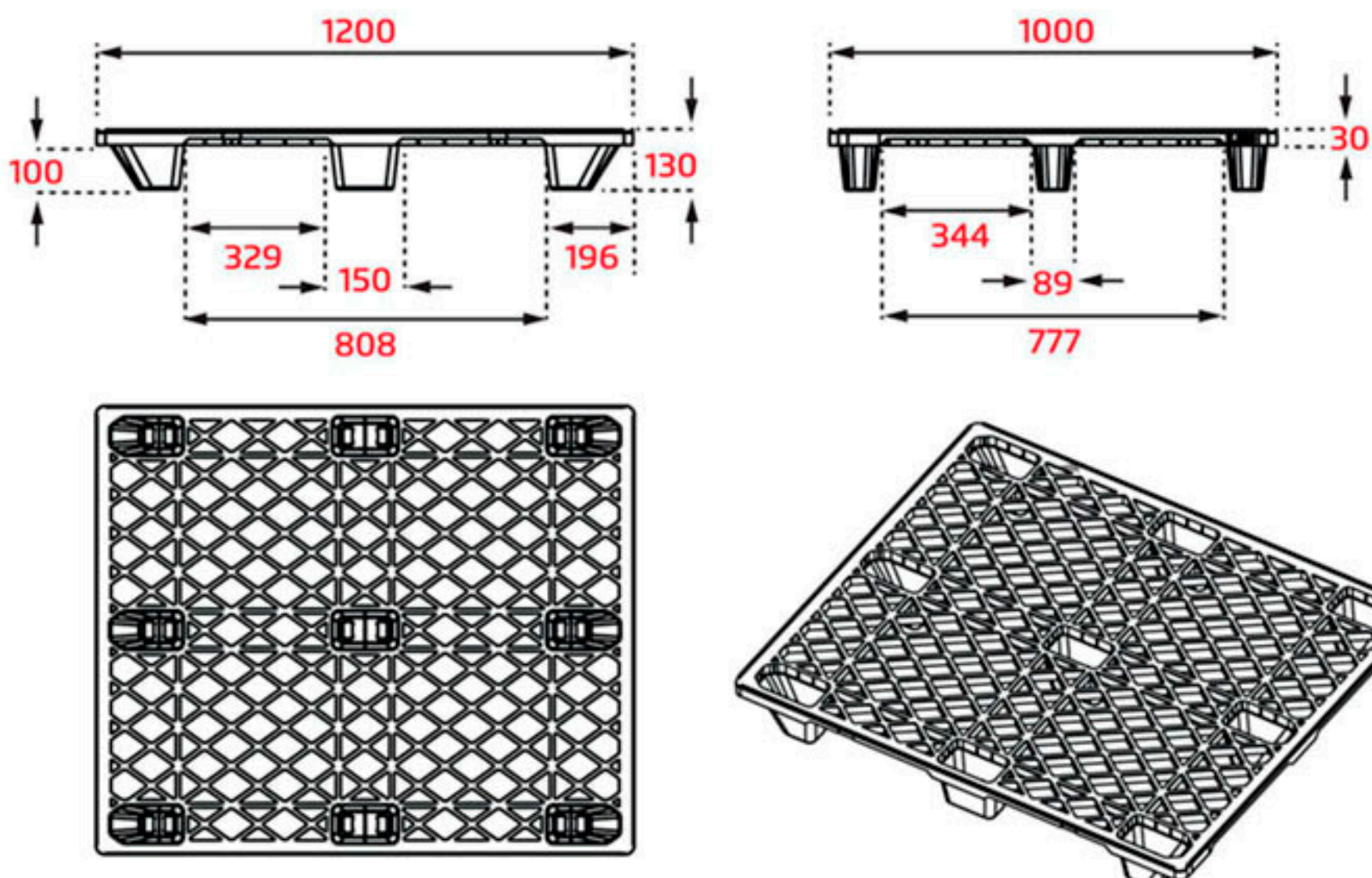

MADE IN ISRAEL

Athanasius Company  
 DISTRIBUIDOR AUTORIZADO  
 EXCLUSIVO PARA LA REPUBLICA ARGENTINA  
 pallets@athanasius-co.com  
 pallets@athanasius.com.ar